

STOP GRUP®

**Bariyer Ürünleri
Barrier Products**

Önce Güven ! Safety First



Özel Askeri Kamp Projesi (Taşınabilir Askeri Kamp)

Private Military Camp Project (Mobile Military Camp)

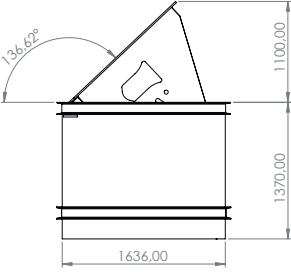

3D Video Link

**STOP GRUP®**www.stopgrup.com

Ürün QR Kodu



Product QR Code

Anti Terör Yol Blok Bariyer

Anti Terror Road Blocker

Gövde Yapısı	: St 37 Çelik
Hareketli Parça	: ST 44 Çelik (15mm)
Çalışma Hızı	: 0,20m/s
Çalışma Voltajı	: 380 V 50 - 60 Hz
Çalışma Sıcaklığı	: -25 + 60°C
Motor Gücü	: 3 - 4 - 5,5kW
Çalışma Sıklığı	: Günlük 500-3000 Tur
Koruma Sınıfı	: IP55
Darbe Dayanımı	: IWA14-1, PAS-68-ASTM2656, K12
Yüzey Kaplama	: Epoksi Boya

Body Structure	: St 37 Steel
Moving Part	: ST 44 Steel (15mm)
Operating Speed	: 0,20m/s
Operating Voltage	: 380 V 50 - 60 Hz
Operational Temperature	: -25 + 60°C
Engine Power	: 3 - 4 - 5,5kW
Operating Frequency	: Daily 500-3000 Cycles
Ingress Protection	: IP55
Impact Resistance	: IWA14-1, PAS-68-ASTM2656, K12
Surface Coating	: Epoxy paint

Makine ve Kimya Endüstrisi Kurumu
Mechanical and Chemical Industry Company

Petkim Aliğa Rafinerisi
Petkim Aliaga Refinery





www.stopgrup.com

STOP BARIYER®





1



2



3





4



5



6



**Maximum Penetration
(dynamic): -1.3m(P1)**

TEST VIDEO

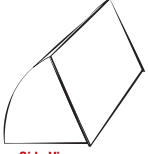
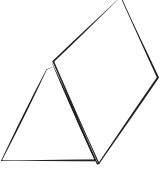

Side View
Yan GörünüşSide View
Yan Görünüş

Ürün QR Kodu



Product QR Code

Yol Blok Bariyer

Gövde Yapısı	: St 37 Çelik
Hareketli Parça	: ST 37/44 Çelik (10/12mm)
Çalışma Hızı	: 0,20m/s
Çalışma Voltajı	: 380 V 50 - 60 Hz
Çalışma Sıcaklığı	: -25 + 60°C
Motor Gücü	: 1,5 - 2,2 - 3kW
Çalışma Sıklığı	: Günlük 500-3000 Tur
Koruma Sınıfı	: IP55
Yüzey Kaplama	: Epoksi Boya
Trafik Işığı	: Ø 100mm

Road Blocker

Body Structure	: St 37 Steel
Moving Part	: ST 37/44 Steel (10/12mm)
Operating Speed	: 0,20m/s
Operating Voltage	: 380 V 50 - 60 Hz
Operational Temperature	: -25 + 60°C
Engine Power	: 1,5 - 2,2 - 3kW
Operating Frequency	: Daily 500 - 3000 Cycles
Ingress Protection	: IP55
Surface Coating	: Epoxy paint
Traffic Light	: Ø 100mm

Kosova NATO Üssü - Kosovo NATO Base



DHMI Türkiye Hava Trafik Kontrol Merkezi - DHMI Turkey Air Traffic Control Center





Ürün QR Kodu



Product QR Code

Teleskopik Yol Blok Bariyer

Telescopic Road Blocker (Shallow Mount Road Blocker)

Gövde Yapısı	: St 37 Çelik
Hareketli Parça	: ST 37/44 Çelik (10/12mm)
Çalışma Hızı	: 0,20m/s
Çalışma Voltajı	: 380 V 50 - 60 Hz
Çalışma Sıcaklığı	: -25 + 60°C
Motor Gücü	: 3 - 4 - 5,5kW
Çalışma Sıklığı	: Günlük 500-3000 Tur
Koruma Sınıfı	: IP55
Yüzey Kaplama	: Elektrostatik Boya
Trafik Işığı	: Ø 100mm

60cm nin üstünde kazı yapılamayacak yerlerde kullanılır

Body Structure	: St 37 Steel
Moving Part	: ST 37/44 Steel (10/12mm)
Operating Speed	: 0,20m/s
Operating Voltage	: 380 V 50 - 60 Hz
Operational Temperature	: -25 + 60°C
Engine Power	: 3 - 4 - 5.5 kW
Operating Frequency	: Daily 500 - 3000 Cycles
Ingress Protection	: IP55
Surface Coating	: Electrostatic paint
Traffic Light	: Ø 100mm

Used in places where no excavation can be performed on 60 centimetres

Deniz Harp Okulu - Turkish Naval Academy





Ürün QR Kodu



Product QR Code

Zemin Üstü Yol Blok Bariyer

On Ground Road Blocker

Gövde Yapısı	: St 37 Çelik
Hareketli Parça	: ST 44 Çelik (10/12mm)
Çalışma Hızı	: 0,20m/s
Çalışma Voltajı	: 380 V 50 - 60 Hz
Çalışma Sıcaklığı	: -25 + 60°C
Motor Gücü	: 3 - 4 - 5,5kW
Çalışma Sıklığı	: Günlük 500-3000 Tur
Koruma Sınıfı	: IP55
Yüzey Kaplama	: Elektrostatik Boya
Trafik Işığı	: Ø 100mm

Body Structure	: St 37 Steel
Moving Part	: ST 44 Steel (10/12mm)
Operating Speed	: 0,20m/s
Operating Voltage	: 380 V 50 - 60 Hz
Operational Temperature	: -25 + 60°C
Engine Power	: 3 - 4 - 5,5kW
Operating Frequency	: Daily 500-3000 Cycles
Ingress Protection	: IP55
Surface Coating	: Electrostatic paint
Traffic Light	: Ø 100mm





Ürün QR Kodu



Product QR Code

Mobil Yol Blok Bariyer

Mobile Road Blocker

Gövde Yapısı	: St 37 Çelik
Hareketli Parça	: ST 44 Çelik (10/12mm)
Çalışma Hızı	: 0,20m/s
Çalışma Voltajı	: 380 V 50 - 60 Hz
Çalışma Sıcaklığı	: -25 + 60°C
Motor Gücü	: 3 - 4 - 5,5kW
Çalışma Sıklığı	: Günlük 500-3000 Tur
Koruma Sınıfı	: IP55
Yüzey Kaplama	: Elektrostatik Boya
Trafik Işığı	: Ø 100mm

Taşınabilir, kurulup-kaldırılabilir.

Body Structure	: St 37 Steel
Moving Part	: ST 44 Steel (10/12mm)
Operating Speed	: 0,20m/s
Operating Voltage	: 380 V 50 - 60 Hz
Operational Temperature	: -25 + 60°C
Engine Power	: 3 - 4 - 5,5kW
Operating Frequency	: Daily 500-3000 Cycles
Ingress Protection	: IP55
Surface Coating	: Electrostatic paint
Traffic Light	: Ø 100mm

Portable, Mobile, Removable.



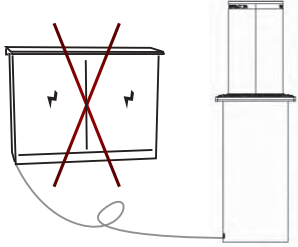

Led'li Alüminyum Kapak

Aluminum Cover With Led

Hareketli parça
Ø273x8mm + 2mm
CR304 paslanmaz çelik
ve ana gövde çapı
324 mm

Moving part is
Ø273x8mm+2mm
CR304 stainless steel
and the main body's
diameter is 324 mm

Hareket eden parça
yüksekliği 600 mm

The height of the
rising part is 600 mm



Ürün QR Kodu



Product QR Code

Elektromekanik Mantar Bariyer (Ünitesi İçinde)

Electromechanical Rising Bollard (Internal Unit)

Çalışma Voltajı	: 230 Vac 50 Hz
Motor	: D.C
Akım	: Min 8 A/ Max 18 A
Maksimum başlangıç Torku	: 63 N.m (1490 N – 152 kg)
Nominal tork	: 40 N.m (950 N – 97 kg)
Motor frekansı	: 36,66 Hz
Motor açılma hızı	: 230 1/s
Redüksiyon oranı	: 1/60
Pinyon dişlisi	: Z : 21 M:4 Db : 84 mm
Koruma Sınıfı	: IP68
Nominal hız	: 0,16 m/s
Saatteki maksimum Tur	: 360
Çalışma süresi	: 4-5min.
Strok	: 600-700mm
Çalışma sıcaklıkları	: -15 °C / + 50 °C
Sınırlama switch tipi	: Endüktif
Elektrik kontrol ünitesi	: PLC
Güvenlik kiti	: Loop dedektör veya fotosel.
Mantar bariyer hareketli kısım	: Ø273x8mm
Dış koruyucu kasa	: Ø324x5mm
Cr 304 Paslanmaz Giydirme	: Ø273x2mm
Üst kapak	: LED ışıklı şeritlerle Alüminyum kapak
Gazlı amörtisör itme kuvveti	: 400N

Working Voltage	: 230 Vac 50 Hz
Engine	: D.C
Current	: Min 8 A/ Max 18 A
Maximum starting torque	: 63 N.m (1490 N – 152 kg)
Nominal torque	: 40 N.m (950 N – 97 kg)
Engine frequency	: 36,66 Hz
Motor angular velocity	: 230 1/s
Reduction ratio	: 1/60
Pinion Gear	: Z : 21 M:4 Db : 84 mm
Ingress Protection	: IP68
Nominal speed	: 0,16 m/s
Maximum turnover per hour	: 360
Total operation period	: 4-5min.
Stroke	: 600-700mm
Operational Temperature	: -15 °C to + 50 °C
Limiting switch type	: Inductive
Electric control unit	: PLC
Security kit	: Loop detector or photocell.
Rising bollard moving part	: Ø273x8mm
External protective casing	: Ø324x5mm
Cr 304 Stainless Covering	: Ø273x2mm
Top cover	: Aluminum cover with LED light strips
Gas damper thrust	: 400N





Ürün QR Kodu



Product QR Code

Hidrolik Mantar Bariyer (Hidrolik Ünitesi Dışında)

Hydraulic Rising Bollards (External Hydraulic Unit)

Çalışma Voltajı	: 380 Vac 50 Hz
Motor Gücü	: 1,5 - 3 - 4 - 5kW
İşlem Başına, dak/maks	: 20/180
Tahrik Sistemi	: Hidrolik
Kaldırma Pistonu	: 40 x 600 x 25
Hidrolik Hortum	: R2 (Çift Helis) 400 Bar
Dayanım Sürekliliği	: %100
Çalışma Ortam Sıcaklığı	: -20 + 55
Koruma Sınıfı	: IP68
Çalışma Hızı	: 3/8" cm/s
Güvenlik Sistemi	: Loop Sensörü, Emniyet fotoseli, LED ışık
Gövde	: Ø323mm ST37 4 mm Derinlik
Hareketli Bariyer Parçası	: Ø273 St44 10mm Üst üst 2mm CR304 sta. çelik
Yüzey Kaplama	: Tüm yüzey sıcak daldırma galvaniz, 2mm CR304 paslanmaz çelik
Montaj	: Sertleştirilmiş taban çevresi dökme beton
Kontroller	: Mikroişlemci kartı, uzaktan kumanda

Working Voltage	: 380 Vac 50 Hz
Engine Power	: 1,5 - 3 - 4 - 5kW
Per Operation, min/max	: 20/180
Drive System	: Hydraulic
Lifting Piston	: 40 x 600 x 25
Hydraulic Hose	: R2 (Double Helix) 400 Bar
Continuity of Durability	: % 100
Operating Temperature	: -20 + 55
Ingress Protection	: IP68
Operating Speed	: 3/8" cm/s
Safety System	: Loop Sensor , Safety photocell , LED light
Body	: Ø323mm ST37 4 mm Steel
Moving Barrier Part	: Ø273 St44 10mm Steel top 2mm CR304 sta. steel
Surface Coating	: All surfaces are hot-dipped galvanized, with 2mm CR304 stainless steel
Assembly	: Cast concrete surrounding hardened base
Controls	: Micro-processor card, remote control





Anahtarla aktive edildiğinde gaz pistonuyla bariyeri yükseltir. Kapatmak için manüel olarak indirilir.

Bariyer kısmı 170mm Çap ve 3 mm kalınlık CR304 paslanmaz çelik. Reflektif bant veya kırmızı LED ışıklı güvenlik bariyeri

Kare bariyer kasası 160mm alüminyum dökümden yapılmıştır

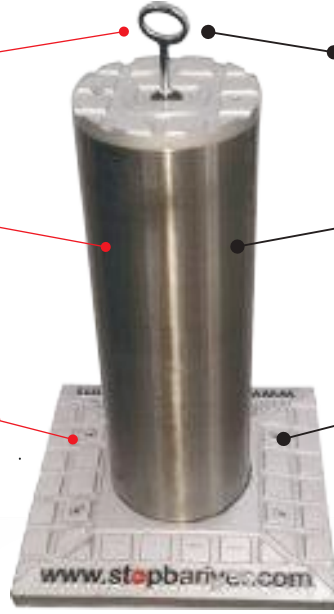

When activated with a key, the barrier rises by gas piston included within the system. Barrier is manually reduced for close

Bollard part consists of 170mm diameter and 3 mm thickness CR304 stainless steel. Reflective band or red Led light can be mounted as for safety on the bollard.

Flange and bollard covers are made of cast 160mm aluminium



Ürün QR Kodu



Product QR Code

Manuel Mekanik Mantar Bariyer

Manual Rising Bollard

- Tahrik Sistemi** : Manüel kontrollü gaz pistonu
- Kaldırma Pistonu** : 27x 500x10 (400N)
- Çalışma Sürekliliği** : 100%
- Çalışma Ortam Sıcaklığı** : -20 + 55
- Güvenlik Sınıfı** : IP68
- Hız** : 16cm / sn
- Manuel Sistem** : Kilit açıldığında, hareketli parça gazla yükseltilir Ayak ile basınç uygulayarak sistem kilitletir.
- Emniyet Sistemi** : Paslanmaz çelik üzeri reflektifli şerit
- Flanş ve Bariyer Örtüsü**: Dökme 160 Alüminyum
- Gövde** : Ø219x4 mm yüzey sıcak daldırma galvanizli
- Hareketli Bariyer Parçası**: 750x170x3mm Cr304 paslanmaz
- Yüzey Kaplama** : Gövde sıcak daldırma galvanizli, hareketli parça CR304 paslanmaz çelik
- Montaj** : Sertleştirilmiş taban çevresi dökme beton
- Kontrol** : Kilitli anahtar

- Drive System** : Manually controlled gas piston
- Lifting Piston** : 27x 500x10(400N)
- Continuity of Working**: 100%
- Operating Temperature** : -20 + 55
- Ingress Protection** : IP68
- Speed** : 16cm/sec
- Manual System** : When the lock opened, moving part is raised with gas pressure The system is locked back by applying pressure with the foot.
- Safety System** : Reflective band over stainless steel
- Flange and Barrier Cover** : Cast 160 Aluminium
- Body** : Ø219x4mm with surface hot dip galvanized
- Moving Part** : 750x170x3mm Cr304 stainless steel
- Surface Coating** : Body is hot dipped galvanized, moving part CR304 sta. steel
- Assembly** : Cast concrete surrounding hardened base
- Controls** : Keylock



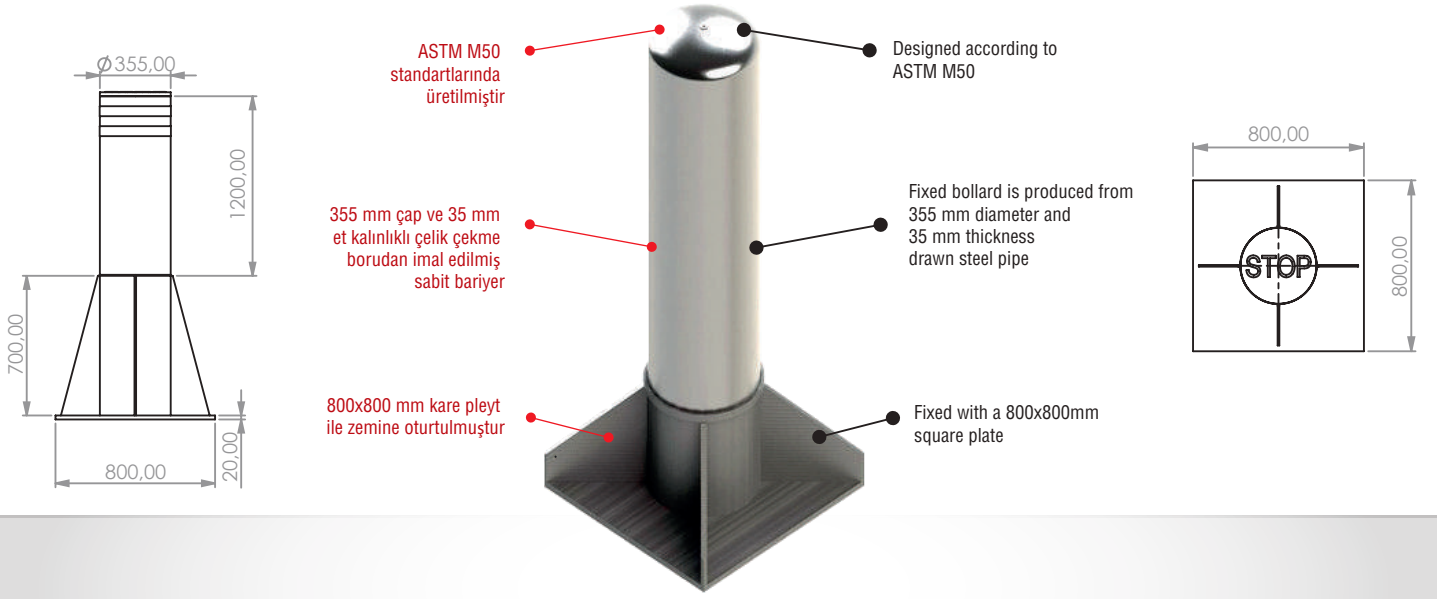

Anti Terör Sabit Bariyer

- Çap** : Ø 355 mm
Bariyer Uzunluğu : 1200 mm
Flaş Derinliği : 700 mm
Pleyt : 800x800x20 mm
Yüzey Kaplama : Sıcak daldırma galvaniz ve elektrostatik toz boya
Montaj : Sertleştirilmiş taban çevresi dökme beton

Anti Terror Fixed Bollard

- Diameter** : Ø 355 mm
Barrier Height : 1200 mm
Flange Deepness : 700 mm
Plate : 800x800x20 mm
Surface Coating : Hot dipped galvanized and electrostatic powder coat
Assembly : Cast concrete surrounding hardened base





Ürün QR Kodu



Product QR Code

Yüksek Güvenlikli Kapı

- > 100 x 100 x 5 mm profil
- > 20'lik çelik halat
- > 22'lik çekme boru
- > 100'lük silindir rulman
- > Rulmanlı yataklama sistemi
- > Manuel veya uzaktan kumanda ile kontrol
- > İstenen ölçüde imalat
- > Motorlu sistem

High Security Gate

- > 100 x 100 x 5 mm profile
- > 20" steel rope
- > 22" drawn pipe
- > 100" roller bearing
- > Roller bearing system
- > Manual or remote control
- > Can be manufactured in desired sizes
- > With Engine





Ürün QR Kodu



Product QR Code

Yüksek Güvenlikli Kapı

- > 100 x 100 x 5 mm profil
- > 20'lik çelik halat
- > 22'lik çekme boru
- > 100'lük silindir rulman
- > Rulmanlı yataklama sistemi
- > Manuel veya uzaktan kumanda ile kontrol
- > İstenen ölçüde imalat
- > Motorlu sistem

High Security Gate

- > 100 x 100 x 5 mm profile
- > 20" steel rope
- > 22" drawn pipe
- > 100" roller bearing
- > Roller bearing system
- > Manual or remote control
- > Can be manufactured in desired sizes
- > With Engine





Ürün QR Kodu



Product QR Code

Stop Kollu Bariyer

Kol Kapasitesi	: 3-4 Metre / 6 Metre
Çalışma Gerilimi	: 230
Motor Gücü	: 190
Motor Tipi	: 24 V Dc
Açma Süresi	: 2,5 - 5 sn
Çalışma Sıklığı	: Sürekli
Koruma Sınıfı	: IP55
Çalışma Sıcaklığı	: -10°/+50°

Uluslar arası standartlara uygun üretim.
Ayarlanabilir fonksiyonlu bariyerler.
Denge Yaylı sistemi ile motor yükü en aza indirilmiştir.
Bariyer kolu her zaman kilitli durumdadır.
Sıkışmaya karşı elektronik güvenlik önlemi.

Stop Boom Barrier

Arm Capacity	: 3-4 Meter / 6 Meter
Working Voltage	: 230
Engine Power	: 190
Engine Type	: 24 V Dc
Opening Time	: 2,5 - 5 sec
Continuity of Working	: Continually
Ingress Protection	: IP55
Working Temperature	: -10°/+50°

Production according to international standards.
Functionally adjustable barriers.
The engine load is reduced to the minimum
with balance spring system.
Barrier's arm is always locked.
Electronic safety measure against jamming.





Ürün QR Kodu



Product QR Code

Anti Terör Kollu Bariyer

Gövde Yapısı	: 20 mm. ST44 çelik
Açma/Kapama	: Kumandalı Hidrolik Sistem (40sn.)
Güvenlik Sınıfı	: IP55
Kol Ebatı	: 350 x 175 x 2.000 - 10.000 mm.
Kol Yüksekliği	: 800 mm.
Gövde Ebatı	: 1500 x 1600 x 1100 mm.
Uyarıcı	: Kırmızı Led, Reflektif Şerit

Uluslararası standartlara uygun üretim. Ayarlanabilir fonksiyonlu bariyerler. Bariyer kolu her zaman kilitli durumdadır. Sıkışmaya karşı elektronik güvenlik önlemi.

Anti Terror Arm Barrier

Body Structure	: 20 mm. ST44 steel
Opening Closing	: Controlled hydraulic system (40sec.)
Security Class	: IP55
Arm Size	: 350 x 175 x 2.000 - 10.000 mm.
Arm Height	: 800 mm.
Body Size	: 1500 x 1600 x 1100 mm.
Warning	: Red Leds, Reflective strip

Production according to international standards. Functionally configurable barriers. The barriers are always locked. Electronic safety measure against jamming.



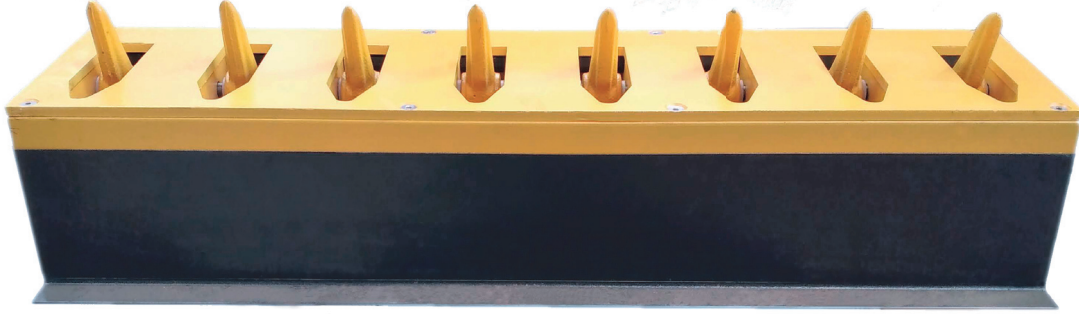

Ürün QR Kodu



Product QR Code

Sessiz Tuzak

Üst Saç	: 6mm ST37
Kayıtlar	: 8mm ST37
Güvenlik Sınıfı	: Orta güvenlik
Ses Tutucu	: Kauçuk Fitol
Yataklama	: Kestamit
Boya	: Ral 1028 Epoksi
Geçiş	: Tek Yönlü
Bıçak Özellikleri	: Özel Dizayn, Sfero döküm bıçak

Özel tasarım sessiz tuzak yol kaparı istenmeyen araçların girişini önlemek veya araç tekerleklerini engelleyen dişleriyle trafiği tek yönlü düzenlemek için kullanılır.

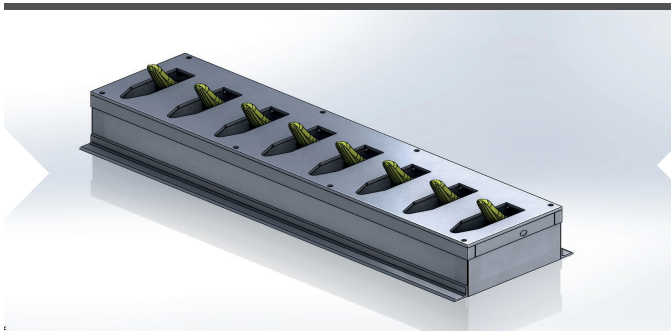

Tire Killer - Quiet Design (Tyre Killer)

Top Structure	: 6mm ST37
Records	: 8mm ST37
Security Class	: Medium security
Sound Holder	: Rubber Wick
Spike Thickness	: Kestamit
Paint	: Ral 1028 Epoxy
Transition	: One Way
Blade Features	: Special Design, Sfero cast blade

Special designed casting tire killers are used to prevent unwanted cars passing or to regulate traffic in a certain direction.

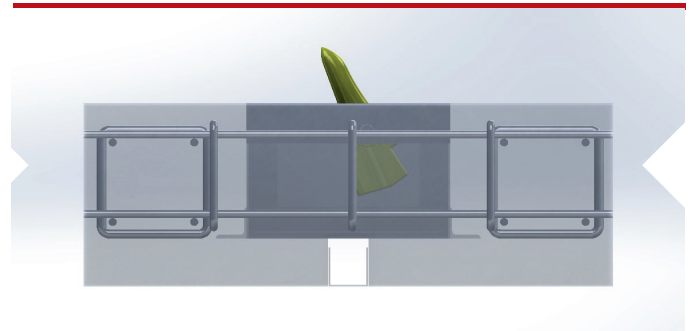

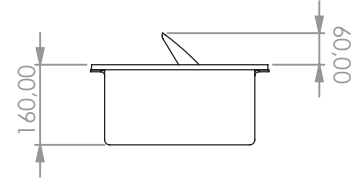
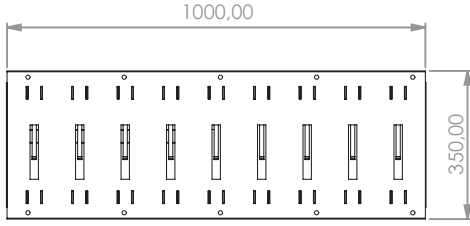

Ürün QR Kodu



Product QR Code

Araç Zemin Altı Yer Tuzağı

Gövde Yapısı	: ST44 çelik
Açma/Kapama	: Manuel
Güvenlik Sınıfı	: Orta güvenlik
Yüzey Kaplama	: Epoksi boya
Mızrak Kalınlığı	: 10mm
Mızrak Yüksekliği	: 65mm

Özel tasarım mızraklı yol kapanı istenmeyen araçların girişini önlemek veya araç tekerleklerini engelleyen dişleriyle trafiği tek yönlü düzenlemek için kullanılır. Manuel olarak kilitlenebilen engellerdir.

Underground Road Trap (Tire Killer)

Body Structure	: ST44 Steel
Opening/Closing	: Manuel lock
Security Class	: Medium security
Surface Coating	: Epoxy paint
Spike Thickness	: 10mm
Spike Height	: 65mm

Special designed tire killers are used to prevent unwanted cars passing or to regulate traffic in a certain direction. These traps are with manual locking system.

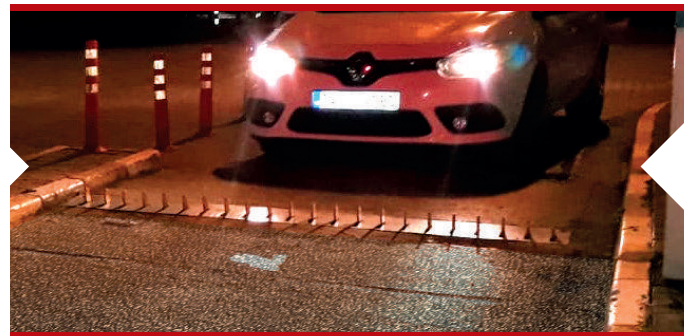
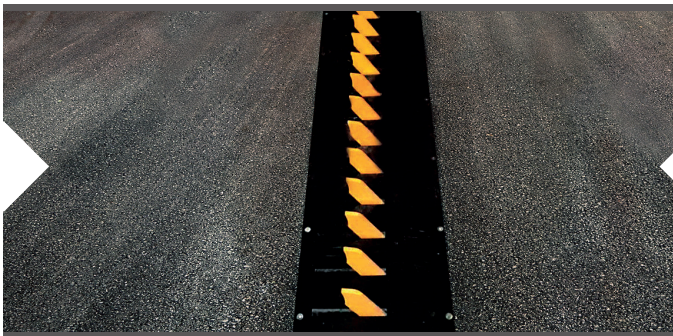

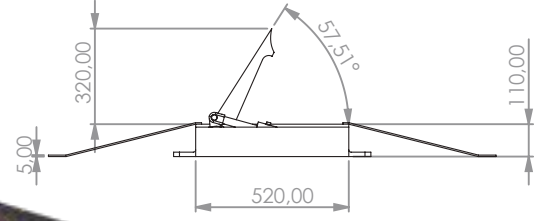

Ürün QR Kodu



Product QR Code

Anti Terör Araç Zemin Üstü Tuzağı

Anti Terror On Ground Road Trap (Tire Killer)

Gövde Yapısı	: 15mm ST44 çelik
Açma/Kapama	: Kumandalı Hidrolik Sistem (2sn.)
Koruma Sınıfı	: IP55
Mızrak Kalınlığı	: St 15mm Çelik
Mızrak Yüksekliği	: 320 mm.
Opsiyonel	: Kontrol Butonu
Dış Kasa	: 520(W) x 110(H) x 2000 / 5000(L)mm.

Özel tasarım mızraklı yol kapama istenmeyen araçların girişini önlemek veya araç tekerleklerini engelleyen dişleriyle trafiği tek yönlü düzenlemek için kullanılır. Kumanda veya buton ile kontrol edilir.

Body Structure	: ST44 Steel
Opening/Closing	: Controlled hydraulic system (2sec.)
Ingress Protection	: IP55
Spike Thickness	: St 15mm Steel
Spike Height	: 320 mm.
Optional	: Control Button
Outside Case	: 520(W) x 110(H) x 2000 / 5000(L)mm.

Special designed tire killers are used to prevent unwanted cars passing or to regulate traffic in a certain direction. Controlled by remote control or buttons.



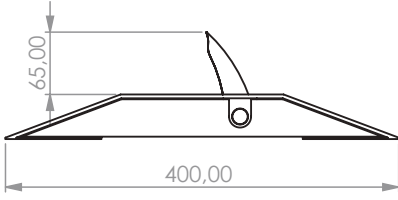

Ürün QR Kodu



Product QR Code

Zemin Üstü Araç Yer Tuzağı

On Ground Road Trap (Tire Killer)

Gövde Yapısı	: ST44 çelik
Açma/Kapama	: Manuel
Güvenlik Sınıfı	: Orta güvenlik
Yüzey Kaplama	: Epoksi boya
Mızrak Kalınlığı	: 10mm
Mızrak Yüksekliği	: 65mm
Panel Boyutu	: 1000mm

Özel tasarım mızraklı yol kapama istenmeyen araçların girişini önlemek veya araç tekerleklerini engelleyen dişleriyle trafiği tek yönlü düzenlemek için kullanılır. Manuel alyan kilitli çalışan engellerdir.

Body Structure	: ST44 Steel
Opening/Closing	: Manuel lock
Security Class	: Medium security
Surface Coating	: Epoxy paint
Spike Thickness	: 10mm
Spike Height	: 65mm
Panel Size	: 1000mm

Special designed tire killers are used to prevent unwanted cars passing or to regulate traffic in a certain direction. These tire killers are manual allen lock working traps.

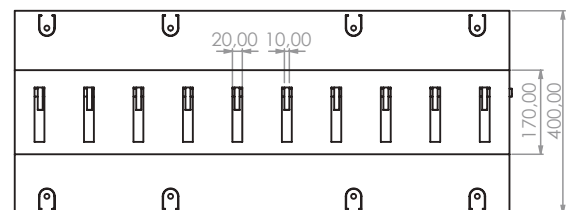
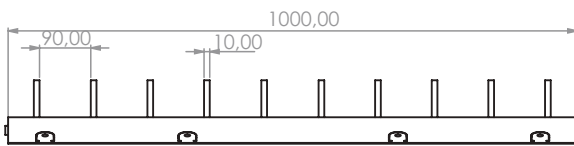

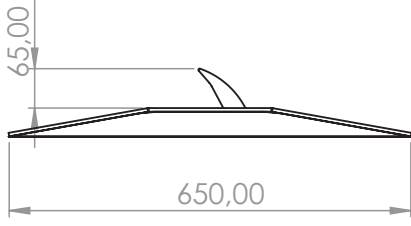

Ürün QR Kodu



Product QR Code

Zemin Üstü Araç Yer Tuzağı

On Ground Road Trap (Tire Killer)

Gövde Yapısı	: ST44 çelik
Açma/Kapama	: Manuel
Güvenlik Sınıfı	: Orta güvenlik
Yüzey Kaplama	: Epoksi boya
Mızrak Kalınlığı	: 10mm
Mızrak Yüksekliği	: 65mm
Panel Boyutu	: 1000mm

Özel tasarım mızraklı yol kapama istenmeyen araçların girişini önlemek veya araç tekerleklerini engelleyen dişleriyle trafiği tek yönlü düzenlemek için kullanılır. Manuel kilitli çalışan engellerdir.

Body Structure	: ST44 Steel
Opening/Closing	: Manuel lock
Security Class	: Medium security
Surface Coating	: Epoxy paint
Spike Thickness	: 10mm
Spike Height	: 65mm
Panel Size	: 1000mm

Special designed tire killers are used to prevent unwanted cars passing or to regulate traffic in a certain direction. These tire killers are manual lock working traps.

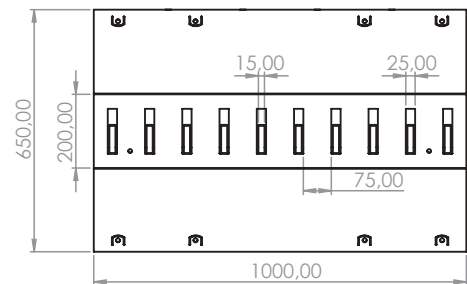
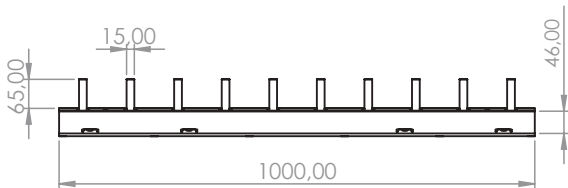



Ürün QR Kodu



Product QR Code

Sabit Bariyerler ve Otopark Ürünleri

- ✓ Pratik Zincirli Bariyer
- ✓ Kilitli Otopark Direği
- ✓ Araç Stoperi
- ✓ Sabit Bariyerler



Fixed Barrier And Parking Products

- ✓ Practical Chained Barrier
- ✓ Locked parking post
- ✓ Vehicle Stopper
- ✓ Fixed Barriers



Referanslar (Bazı Referanslarımız)



References (Some of our references)



STOP GRUP A.Ş.

www.stopgrup.com

STOP BARIYER

www.stopbariyer.com

STOP ÇİT

www.stopcit.com

STOP SPOR

www.stopspor.com

STOP ENERJİ

www.stopenerji.com

STOP İNŞAAT

www.stopinsaat.com

STOP TRAFİK

www.stoptrafik.com

Stop Grup Güvenlik Sistemleri İnş. San. Tic. ve A.Ş.

Güzelce Mahallesi İskenderun Caddesi No:6 E-5 Üzeri
(Güzelce Kavşağı Yanı) Büyükçekmece - İstanbul / Türkiye

+90 212 868 08 90-91

+90 212 868 08 87

info@stopgrup.com



Address QR Code